



3D Computer Vision II

Two View Geometry Part 1 – Epipolar Geometry

Nassir Navab

based on a course given at UNC by Marc Pollefeys & the book "Multiple View Geometry" by Hartley & Zisserman

October 28, 2010

Motivation

- (i) **Correspondence geometry:** Given an image point x in the first view, how does this constrain the position of the corresponding point x' in the second image?

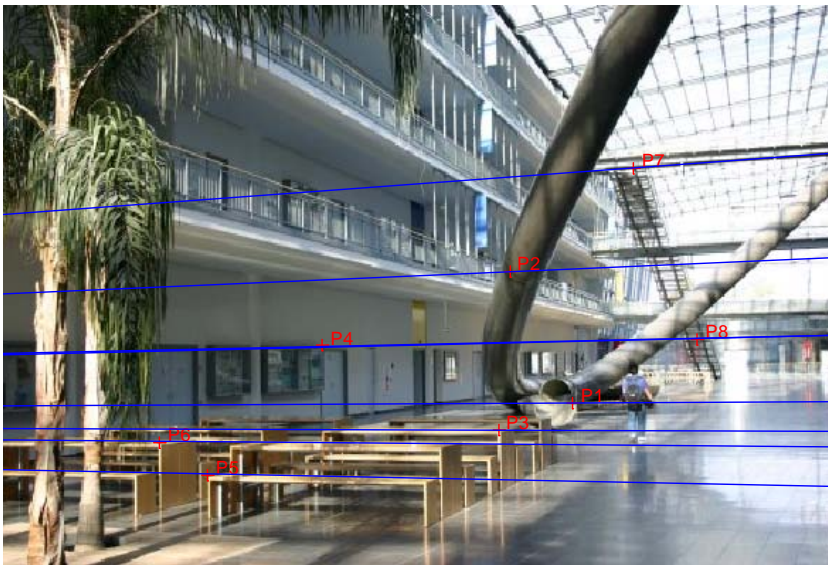

Motivation

(ii) **Camera geometry (motion):** Given a set of corresponding image points $\{x_i \leftrightarrow x'_i\}$, $i=1, \dots, n$, what are the cameras P and P' for the two views?

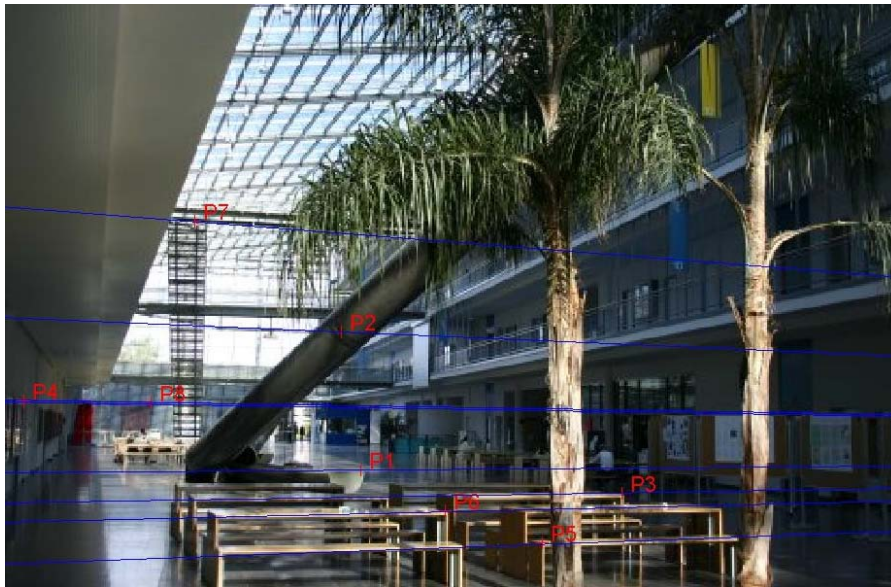

Motivation

- (iii) **Scene geometry (structure):** Given corresponding image points $x_i \leftrightarrow x'_i$ and cameras P, P' , what is the position of (their pre-image) X in space?



Outline – Two-View Geometry

- Epipolar Geometry
- 3D Reconstruction
- Fundamental Matrix Computation



The Epipolar Geometry

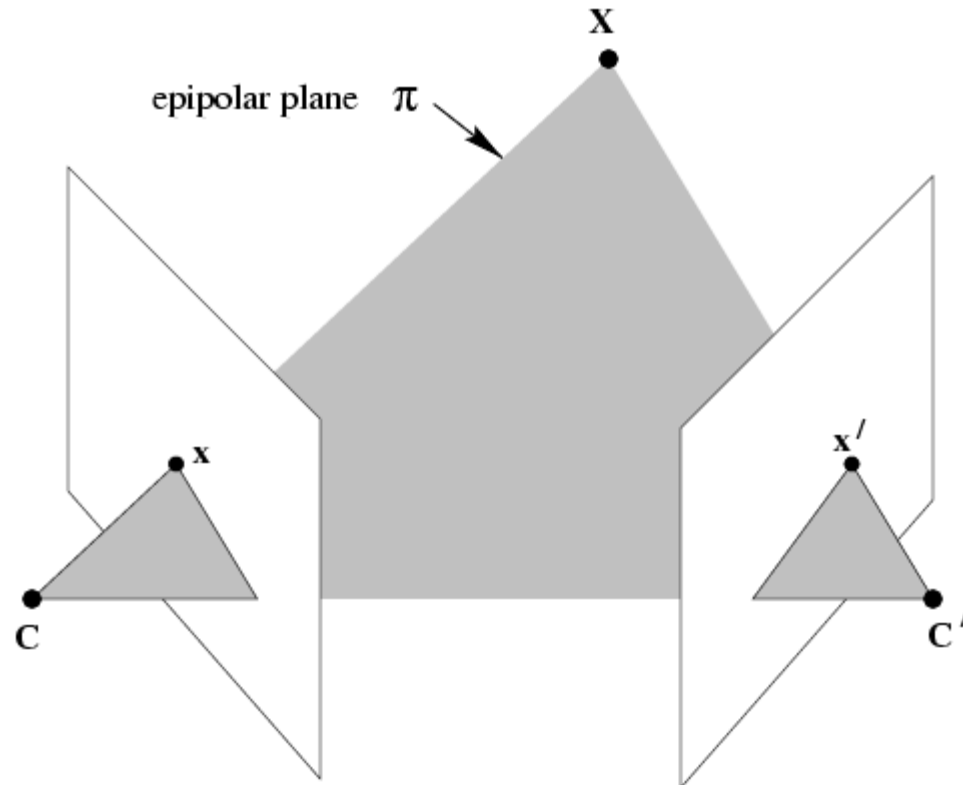

C , C' , x , x' and X are coplanar

The Epipolar Geometry

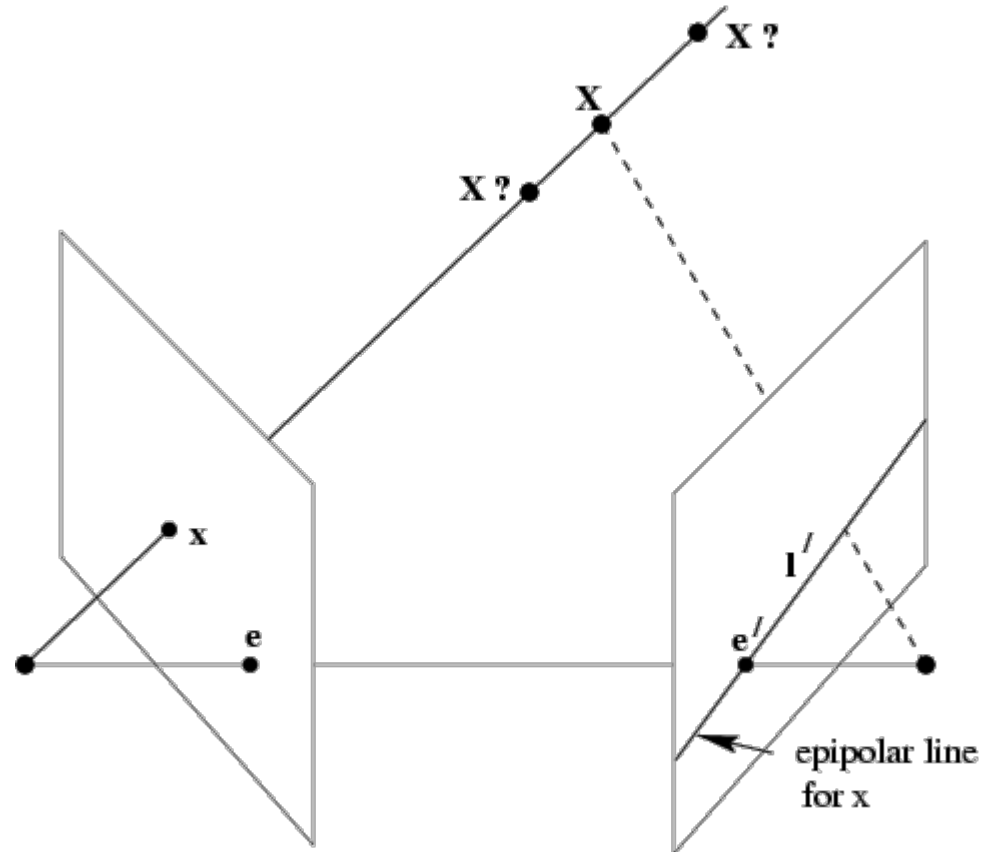

What if only C , C' , x are known?

The Epipolar Geometry

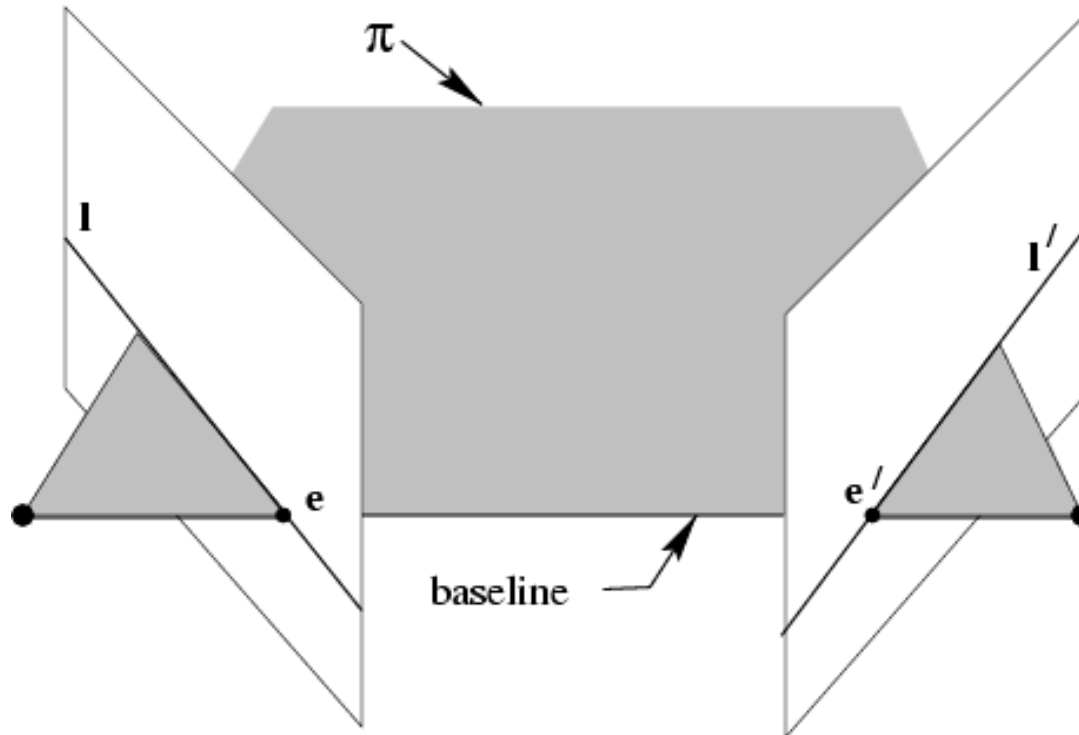

All points on π project on l and l'

The Epipolar Geometry

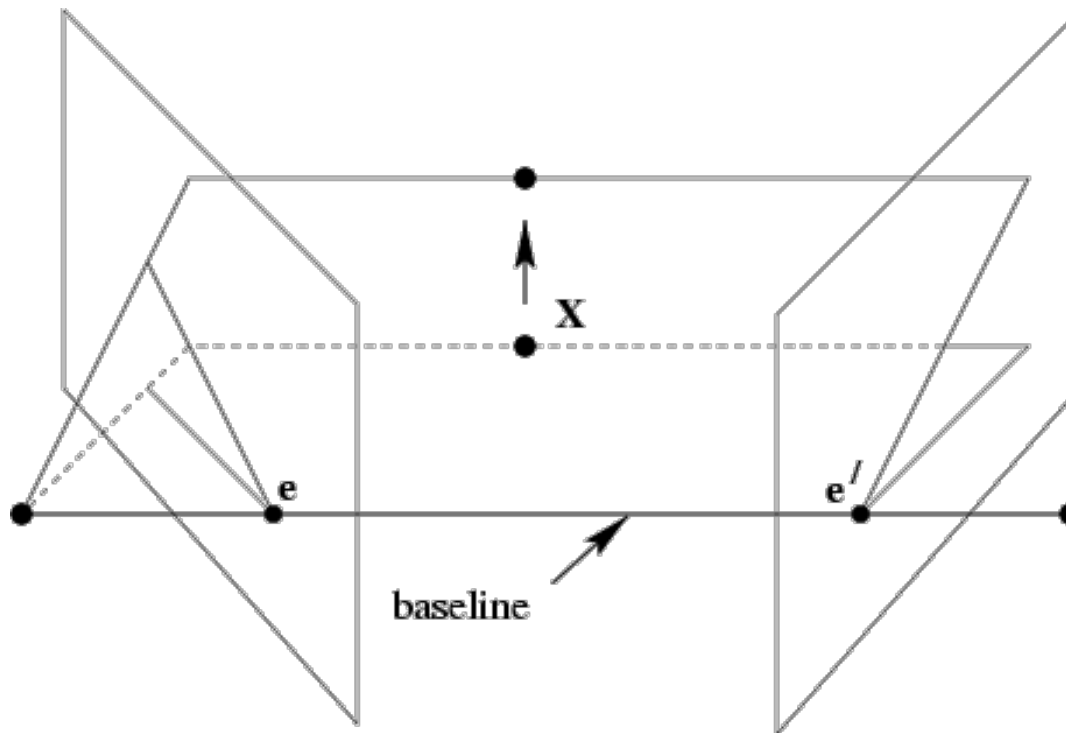

Family of planes π and lines l and l'
Intersection in e and e'

The Epipolar Geometry

Epipoles e, e'

- = intersection of baseline with image planes
- = projection of one projection center in the other image
- = vanishing point of camera motion direction

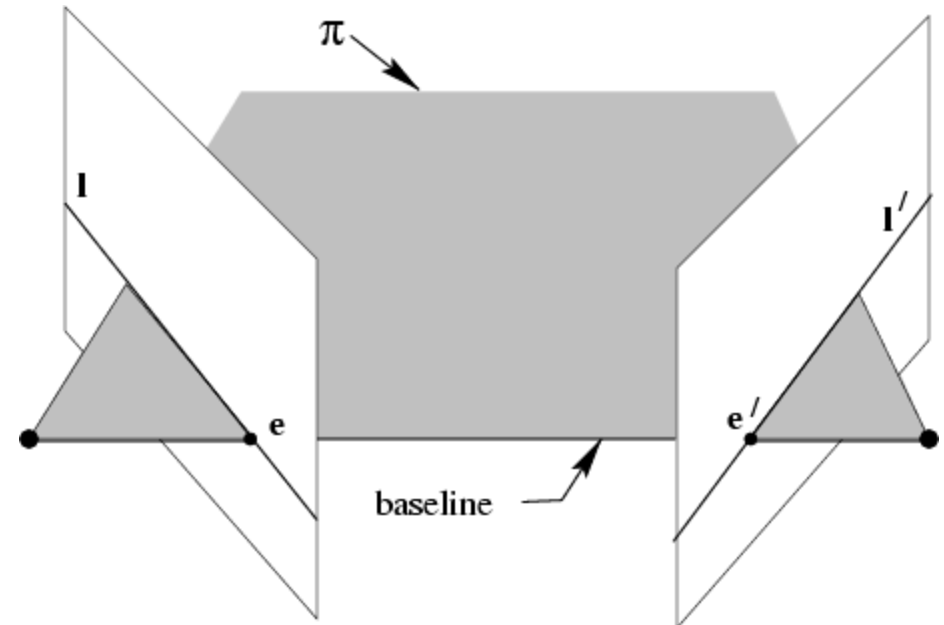

An epipolar plane = plane containing baseline (1-D family)

An epipolar line = intersection of epipolar plane with image
(always come in corresponding pairs)

Example: Converging Cameras

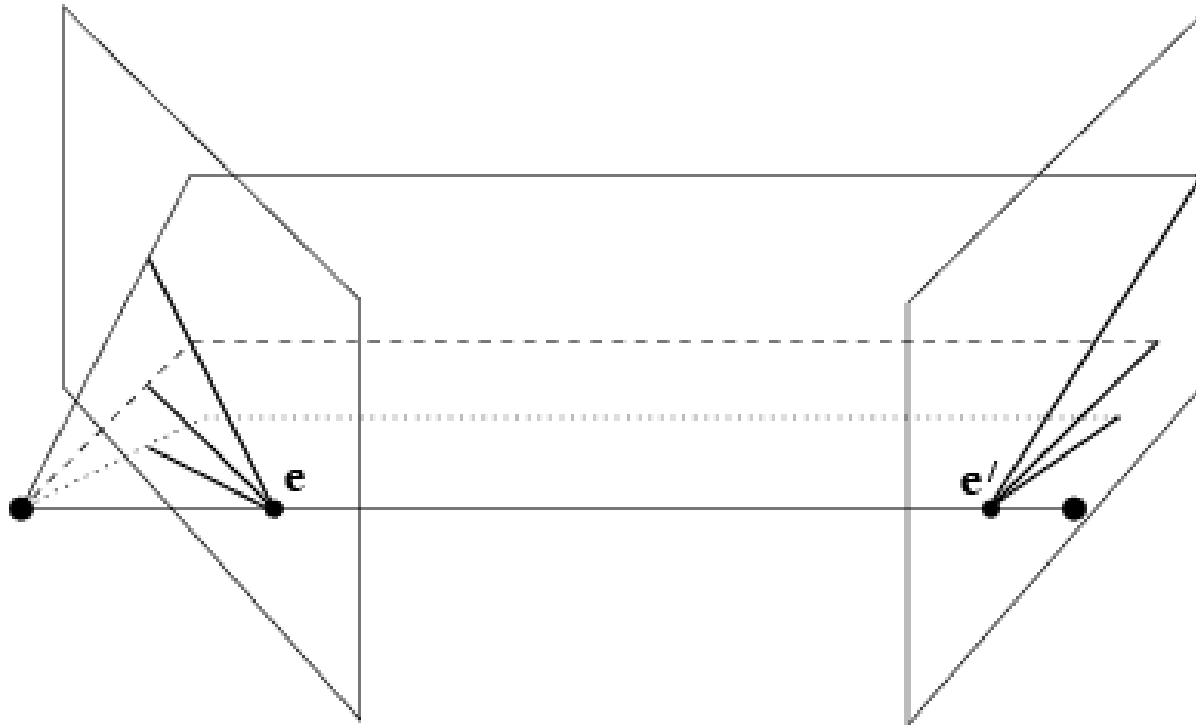

Example: Converging Cameras



The Fundamental Matrix F

Algebraic representation of Epipolar Geometry:

$$\mathbf{x} \mapsto \mathbf{l}'$$

We will see that mapping is (singular) correlation (i.e. projective mapping from points to lines) represented by the fundamental matrix F

Points from Lines and Vice-versa

- Intersections of lines

The intersection of two lines l and l' is $x = l \times l' = [l]_x l' = -[l']_x l$

- Line joining two points

The line through two points x and x' is $l = x \times x' = [x]_x x' = -[x']_x x$

- Anti-symmetric Matrix

$$[l]_x = \begin{bmatrix} 0 & -l_3 & l_2 \\ l_3 & 0 & -l_1 \\ -l_2 & l_1 & 0 \end{bmatrix}$$

Example

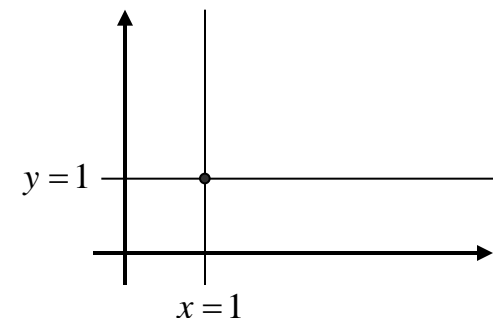

The Fundamental Matrix F – Geometric Derivation

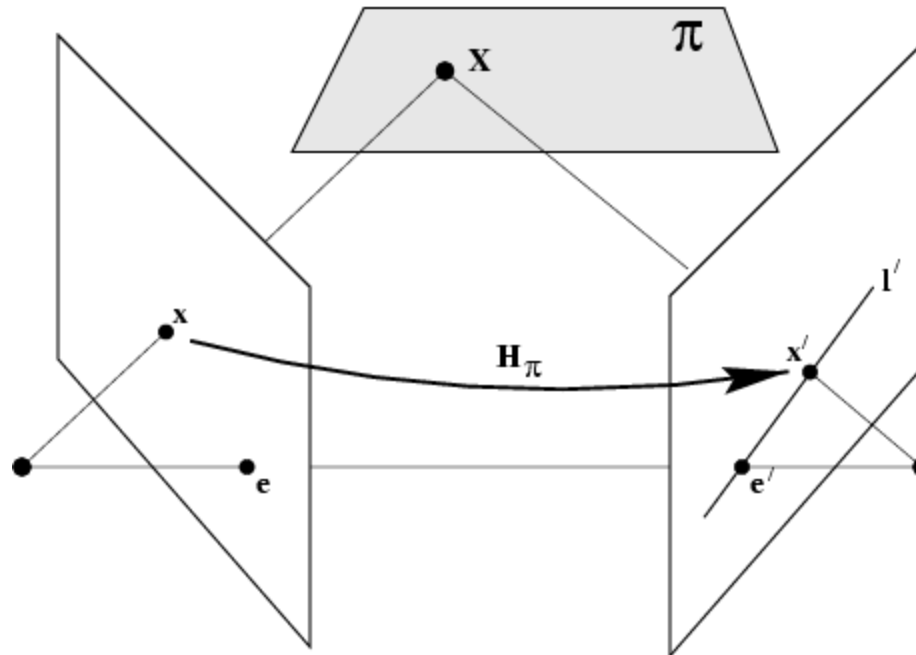

$$x' = H_{\pi} x$$

$$l' = e' \times x' = [e']_{\times} H_{\pi} x = Fx$$

Mapping from 2-D to 1-D family (rank 2)

The Fundamental Matrix F

Algebraic derivation:

$$X(\lambda) = P^+ x + \lambda C \quad (PP^+ = I)$$

$$l' = P' C \times P' P^+ x$$

$$F = [e']_x P' P^+$$

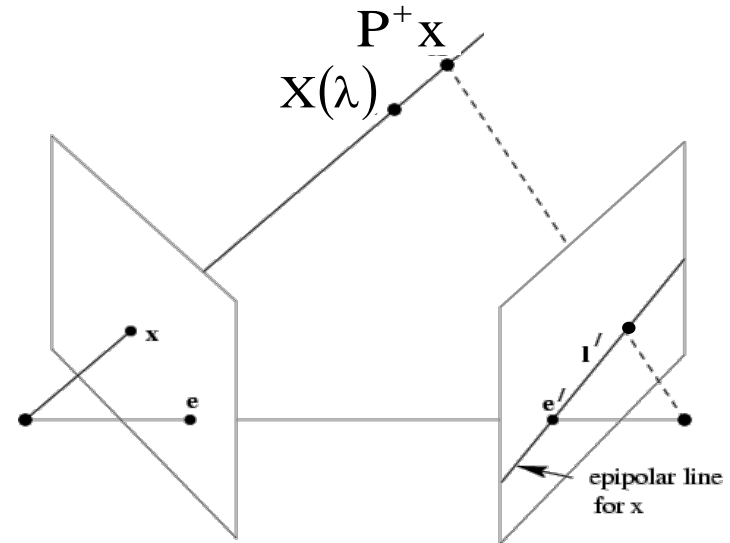

(note: doesn't work for $C=C' \Rightarrow F=0$)

The Fundamental Matrix F

Correspondence condition:

The fundamental matrix satisfies the condition that for any pair of corresponding points $x \leftrightarrow x'$ in the two images:

$$\mathbf{x}'^T \mathbf{F} \mathbf{x} = 0 \quad (\mathbf{x}'^T \mathbf{1}' = 0)$$

The Fundamental Matrix F

F is the unique 3×3 rank 2 matrix that satisfies $x'^T F x = 0$ for all $x \leftrightarrow x'$.

- (i) **Transpose:** if F is fundamental matrix for (P, P') , then F^T is fundamental matrix for (P', P)
- (ii) **Epipolar lines:** $l' = Fx$ & $l = F^T x'$
- (iii) **Epipoles:** on all epipolar lines, thus $e'^T F x = 0, \forall x \Rightarrow e'^T F = 0$, similarly $F e = 0$
- (iv) F has 7 d.o.f. , i.e. $3 \times 3 - 1$ (homogeneous) - 1 (rank 2)
- (v) F is a correlation, projective mapping from a point x to a line $l' = Fx$ (not a proper correlation, i.e. not invertible)

The Epipolar Line Geometry

l, l' epipolar lines, k line not through e
 $\Rightarrow l' = F[k]_{\times} l$ and symmetrically $l = F^T[k']_{\times} l'$

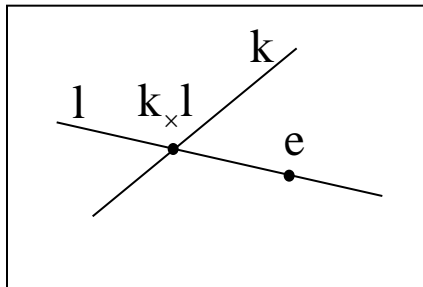

$$l' = F[e]_{\times} l$$

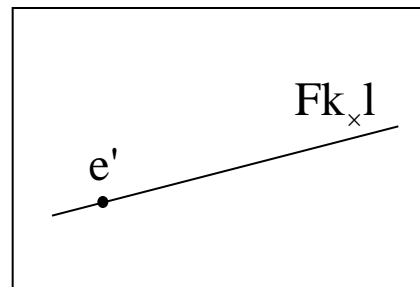

$$l = F^T[e']_{\times} l'$$

(pick $k=e$, since $e^T e \neq 0$)

Fundamental Matrix for Pure Translation

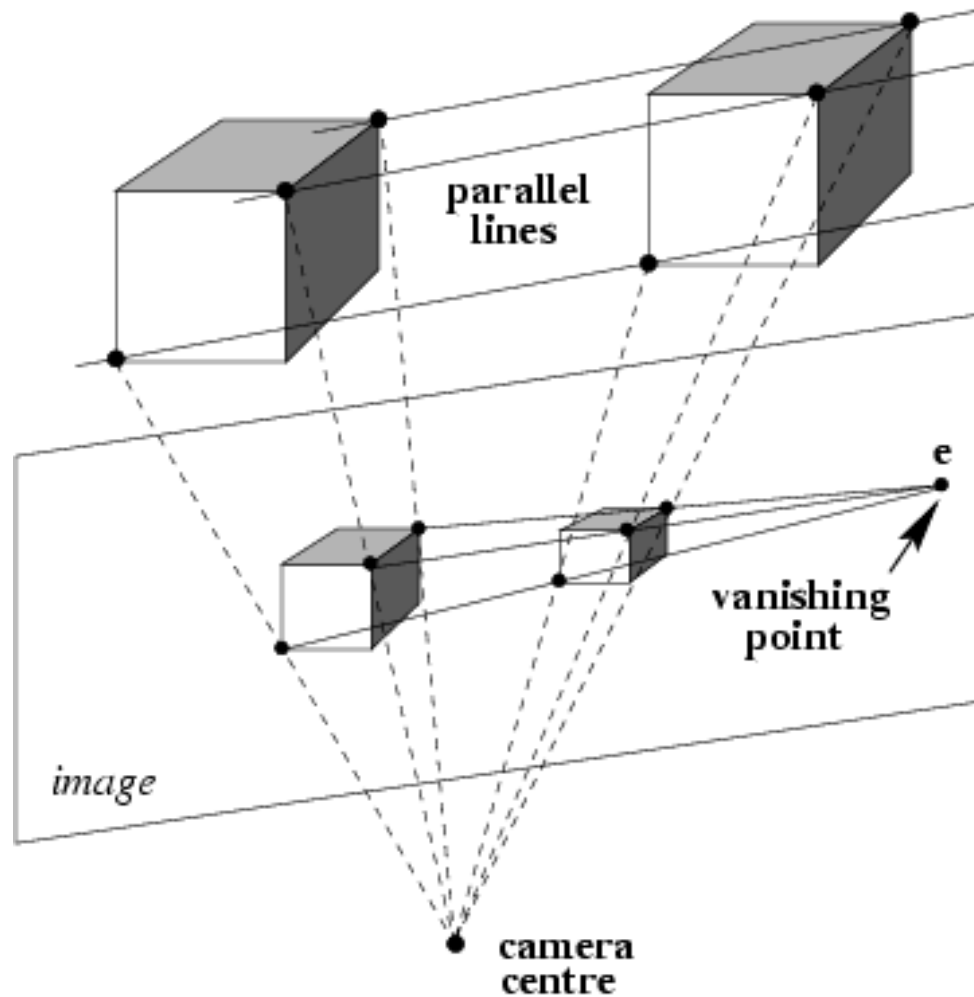

Example: Motion Parallel with Image Plane

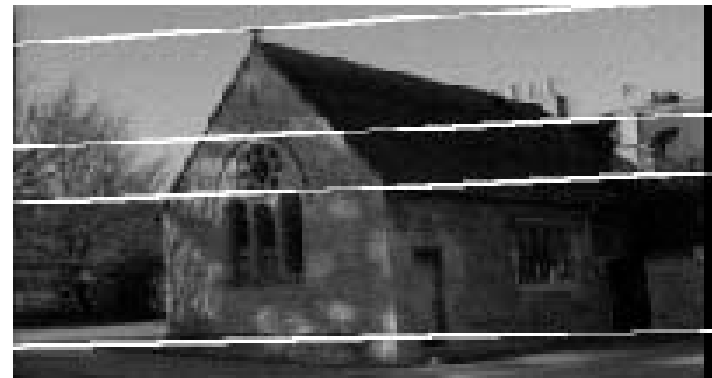
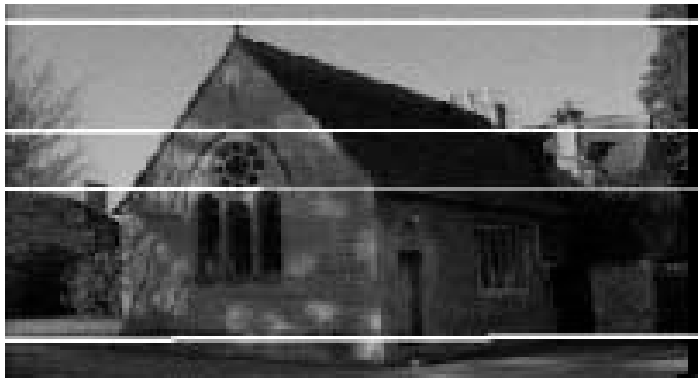
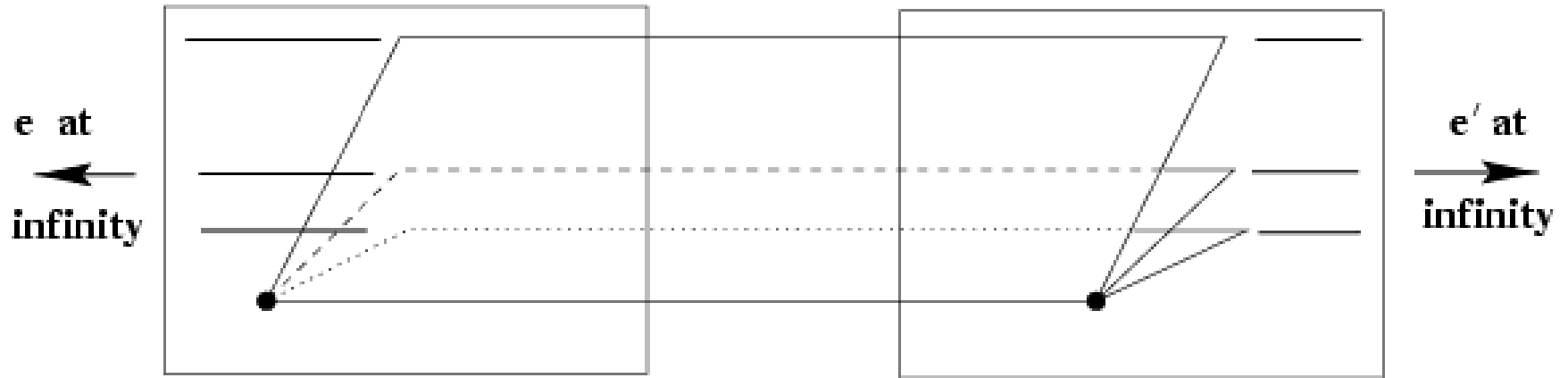

Example: Forward Motion

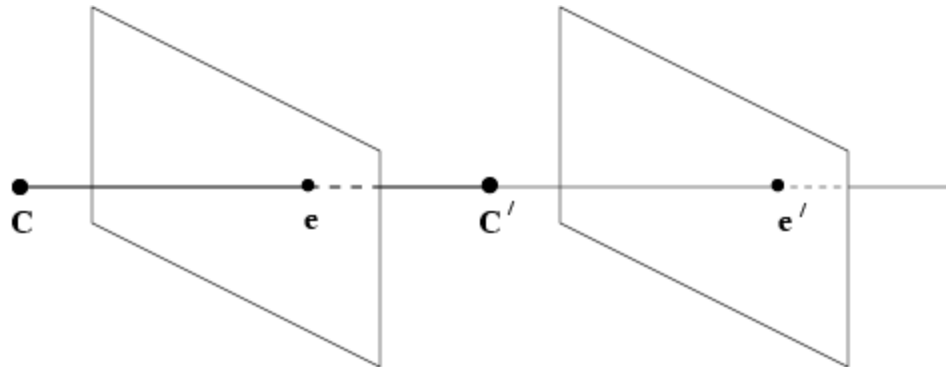
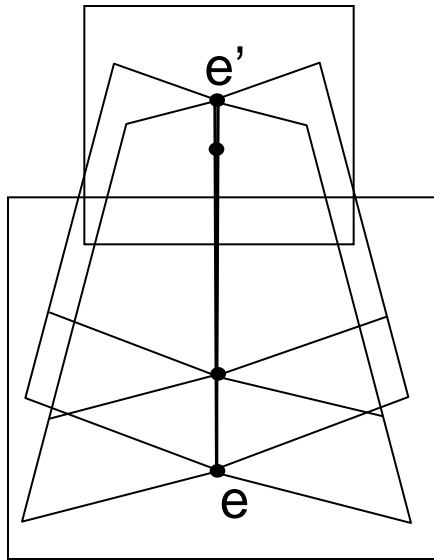

Fundamental Matrix for Pure Translation

$$F = [e']_x P' P^+$$

$$P' P^+ = P' P^t (P P^t)^{-1} = K [I|T] \begin{bmatrix} I \\ 0 \end{bmatrix} K^t K^{-t} K^{-1} = K K^{-1}$$

$$F = [e']_x K K^{-1} = [e']_x$$

Fundamental Matrix for Pure Translation

$$F = [e']_x H_\infty = [e']_x \quad (H_\infty = K R K^{-1})$$

Fundamental Matrix for Pure Translation

$$F = [e']_x K K^{-1} = [e']_x$$

Example:

$$e' = (1, 0, 0)^T \quad F = \begin{bmatrix} 0 & 0 & 0 \\ 0 & 0 & -1 \\ 0 & 1 & 0 \end{bmatrix}_x$$

$$x'^T F x = 0 \Leftrightarrow y = y'$$

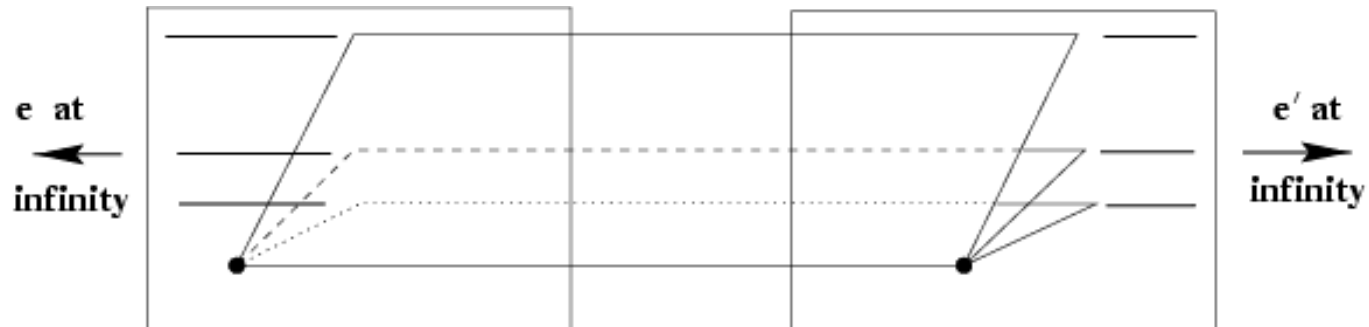

Fundamental Matrix for Pure Translation

$$F = [e']_x K K^{-1} = [e']_x$$

$$x = P X = K [I | 0] X$$

$$x' = P' X = K [I | t] \begin{bmatrix} K^{-1} x \\ 1/Z \end{bmatrix}$$

$$(X, Y, Z)^T = Z K^{-1} x$$

$$x' = x + K t / Z$$

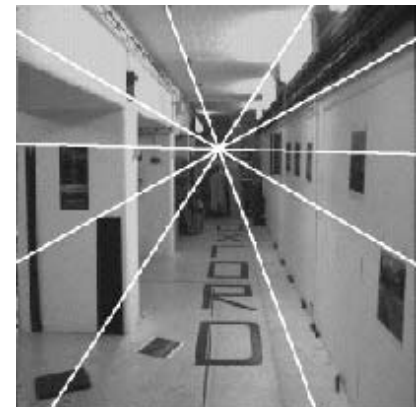
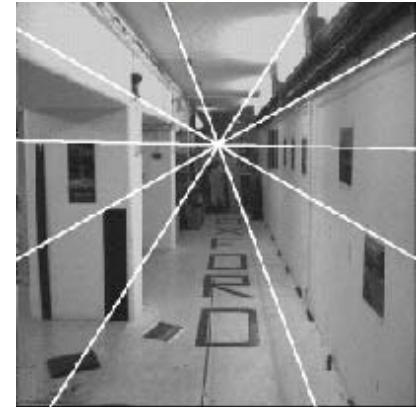

Motion starts at x and moves towards e , faster depending on Z

Fundamental Matrix for Pure Translation

$$F = [e']_x K K^{-1} = [e']_x$$

Pure translation:

F only 2 d.o.f.

$$x^T [e]_x x = 0 \Rightarrow \text{auto-epipolar}$$

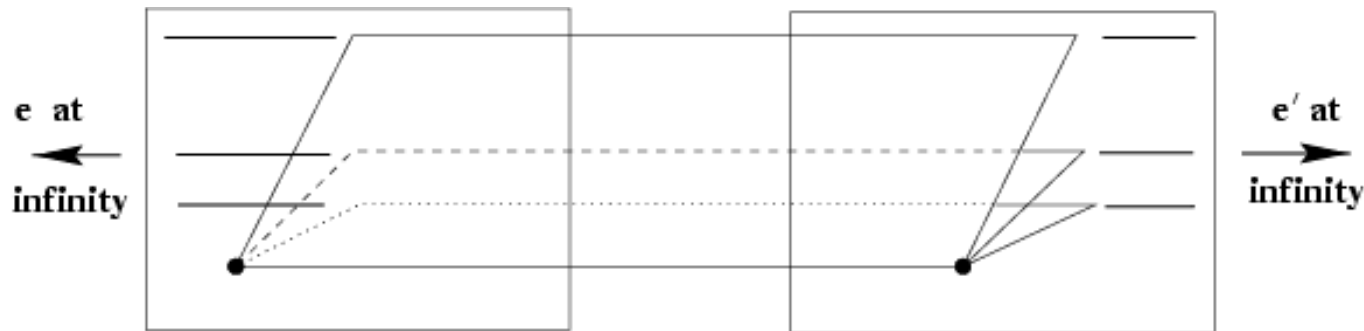

General Motion

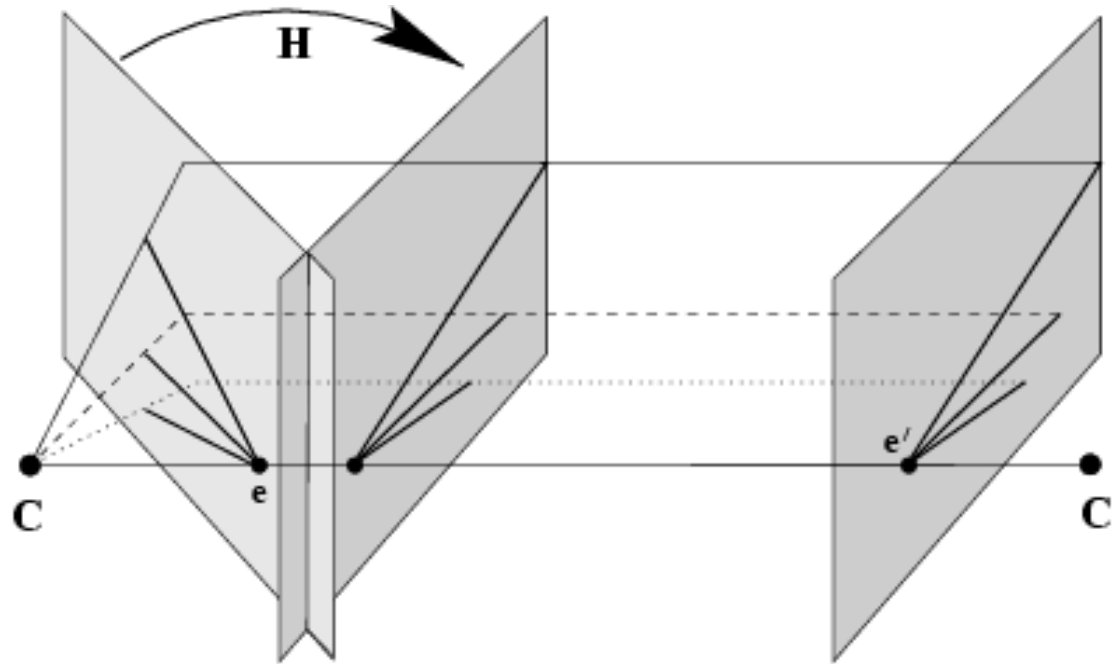

$$\mathbf{x}'^T [\mathbf{e}']_{\times} \mathbf{H} \mathbf{x} = 0$$

$$\mathbf{x}'^T [\mathbf{e}']_{\times} \hat{\mathbf{x}} = 0$$

$$\mathbf{x}' = \mathbf{K}' \mathbf{R} \mathbf{K}^{-1} \mathbf{x} + \mathbf{K}' \mathbf{t} / Z$$

Projective Transformation and Invariance

Derivation based purely on projective concepts

$$\hat{x} = Hx, \hat{x}' = H'x' \Rightarrow \hat{F} = H'^{-T} FH^{-1}$$

$$\hat{x}^T \hat{F} \hat{x}' = x^T H^T \hat{F} H' x' = x^T F x' = 0$$

$$\Rightarrow \hat{F} = H'^{-T} FH^{-1}$$

F is not invariant to transformations of projective 2-space

Projective Transformation and Invariance

F is invariant to transformations of projective 3-space

$$\mathbf{x} = \mathbf{P}\mathbf{X} = (\mathbf{P}\mathbf{H})(\mathbf{H}^{-1}\mathbf{X}) = \hat{\mathbf{P}}\hat{\mathbf{X}}$$

$$\mathbf{x}' = \mathbf{P}'\mathbf{X} = (\mathbf{P}'\mathbf{H})(\mathbf{H}^{-1}\mathbf{X}) = \hat{\mathbf{P}}'\hat{\mathbf{X}}$$

canonical form

$$\begin{array}{l} \mathbf{P} = [\mathbf{I} \mid \mathbf{0}] \\ \mathbf{P}' = [\mathbf{M} \mid \mathbf{m}] \end{array} \quad \mathbf{F} = [\mathbf{e}']_{\times} \mathbf{P}' \mathbf{P}^+ \quad \longrightarrow \quad \mathbf{F} = [\mathbf{m}]_{\times} \mathbf{M}$$

Projective Transformation and Invariance

F is invariant to transformations of projective 3-space

$$\mathbf{x} = \mathbf{P}\mathbf{X} = (\mathbf{P}\mathbf{H})(\mathbf{H}^{-1}\mathbf{X}) = \hat{\mathbf{P}}\hat{\mathbf{X}}$$

$$\mathbf{x}' = \mathbf{P}'\mathbf{X} = (\mathbf{P}'\mathbf{H})(\mathbf{H}^{-1}\mathbf{X}) = \hat{\mathbf{P}}'\hat{\mathbf{X}}$$

canonical form

$$\begin{array}{l} \mathbf{P} = [\mathbf{I} \mid \mathbf{0}] \\ \mathbf{P}' = [\mathbf{M} \mid \mathbf{m}] \end{array} \quad \mathbf{F} = [\mathbf{e}']_{\times} \mathbf{P}' \mathbf{P}^+ \quad \longrightarrow \quad \mathbf{F} = [\mathbf{m}]_{\times} \mathbf{M}$$

$$(\mathbf{P}, \mathbf{P}') \mapsto \mathbf{F} \quad \text{unique}$$

$$\mathbf{F} \mapsto (\mathbf{P}, \mathbf{P}') \quad \text{not unique}$$

Projective Ambiguity of Cameras Given F

Previous slide: at least projective ambiguity!

This slide: no more than that!

Let us show that if F is same for (P, P') and (\tilde{P}, \tilde{P}') , there exists a projective transformation H so that $\tilde{P} = HP$ and $\tilde{P}' = HP'$.

Projective Ambiguity of Cameras Given F

$$P = [I \mid 0], P' = [A \mid a]$$

$$\tilde{P} = [I \mid 0], \tilde{P}' = [\tilde{A} \mid \tilde{a}]$$

$$F = [a]_{\times} A = [\tilde{a}]_{\times} \tilde{A}$$

Lemma:

$$\tilde{a} = ka$$

$$\tilde{A} = k^{-1}(A + av^T)$$

Projective Ambiguity of Cameras Given F

$$P = [I | 0], P' = [A | a]$$

$$\tilde{P} = [I | 0], \tilde{P}' = [\tilde{A} | \tilde{a}]$$

$$F = [a]_{\times} A = [\tilde{a}]_{\times} \tilde{A}$$

Lemma:

$$\tilde{a} = ka$$

$$\tilde{A} = k^{-1}(A + av^T)$$

$$a^T F = a^T [a]_{\times} A = 0 = \tilde{a}^T F \stackrel{\text{rank } 2}{\implies} \tilde{a} = ka$$

Projective Ambiguity of Cameras Given F

$$P = [I \mid 0], P' = [A \mid a]$$

Lemma:

$$\tilde{P} = [I \mid 0], \tilde{P}' = [\tilde{A} \mid \tilde{a}]$$

$$\tilde{a} = ka$$

$$F = [a]_{\times} A = [\tilde{a}]_{\times} \tilde{A}$$

$$\tilde{A} = k^{-1}(A + av^T)$$

$$aF = a[a]_{\times} A = 0 = \tilde{a}F \stackrel{\text{rank } 2}{\implies} \tilde{a} = ka$$

$$[a]_{\times} A = [\tilde{a}]_{\times} \tilde{A} \implies [a]_{\times} (k\tilde{A} - A) = 0$$

$$\implies (k\tilde{A} - A) = av^T$$

Projective Ambiguity of Cameras Given F

Let us show that if F is same for (P, P') and (\tilde{P}, \tilde{P}') , there exists a projective transformation H so that $P = H\tilde{P}$ and $P' = H\tilde{P}'$.

$$P = [I \mid 0], P' = [A \mid a]$$

$$\tilde{P} = [I \mid 0], \tilde{P}' = [\tilde{A} \mid \tilde{a}]$$

$$H = \begin{bmatrix} k^{-1}I & 0 \\ k^{-1}\mathbf{v}^T & k \end{bmatrix}$$

$$P' H = [A \mid a] \begin{bmatrix} k^{-1}I & 0 \\ k^{-1}\mathbf{v}^T & k \end{bmatrix} = [k^{-1}(A + a\mathbf{v}^T) \mid ka] = \tilde{P}'$$

Projective Ambiguity of Cameras Given F

Let us show that if F is same for (P, P') and (\tilde{P}, \tilde{P}') , there exists a projective transformation H so that $P = H\tilde{P}$ and $P' = H\tilde{P}'$.

Makes also sense with regard to the degrees of freedom:

$$\underbrace{2 \times 11}_{P, P'} - \underbrace{15}_H = \underbrace{22}_{\tilde{P}, \tilde{P}'} - \underbrace{15}_F = 7$$

Canonical Cameras Given F

Possible choice:

$$P = [I | 0] \quad P' = [[e']_{\times} F | e']$$

$$P = [I | 0], P' = [A | a]$$

$$\tilde{P} = [I | 0], \tilde{P}' = [\tilde{A} | \tilde{a}]$$

$$F = [a]_{\times} A = [\tilde{a}]_{\times} \tilde{A}$$

Lemma:

$$\tilde{a} = ka$$

$$\tilde{A} = k^{-1}(A + av^T)$$

Canonical representation:

$$P = [I | 0]$$

$$P' = [[e']_{\times} F + e'v^T | \lambda e']$$

The Essential Matrix

~ Fundamental matrix for calibrated cameras (remove K)

$$E = [t]_{\times} R = R[R^T t]_{\times}$$

$$\hat{x}'^T E \hat{x} = 0 \quad \left(\hat{x} = K^{-1}x; \hat{x}' = K^{-1}x' \right)$$

$$E = K'^T F K$$

5 d.o.f. (3 for R; 2 for “t up to scale”)

E is essential matrix if and only if two singular values are equal (and third=0).

$$E = U \text{diag}(1,1,0) V^T$$